

---

**75 W High-End Current Drive Audio Amplifier with MFB\* Control Loop**

---

**75 W Power Amplifier with Motion Feed Back (MFB)\* Control Loop for Cone Drivers**

- Very High AC Supply Voltage Range
- DMOS Power Stage (Class AB)
- High Output Power >75 W rms
- Very Low Distortion and Noise
- **Integrated MFB\* controller**
- **Self-adjustment of a wide range of sensor offset voltages <sup>1)</sup>**
- Differential Audio Input
- Adjustable Input Sensitivity
- On-board Muting/Standby-Function
- Thermal Protection / Shutdown
- Clip Detector / Visualization with LED
- RoHS compliant, IPC-A-600 Class 2 and IPC-A-610 Class 2



**Figure 1: Driver Module AC-PAR75 on mounting flange (PCB Version 6)**

**Description / Novel Features**

The AC-PAR75 is a very compact, high-end, class AB audio power amplifier with excellent linearity and low distortion, combined with a perfect flat audio frequency response, and low noise.

**The AC-PAR75 Power Amplifier offers - as novelty and different to any other power amplifier - the complete integrated control circuit for the Motion Feed Back (MFB) of the connected dynamic loudspeaker.**

A small separate PCB with low mass carries the sensor for the MFB, which delivers the input signal for the MFB controller onboard the AC-PAR75. This small PCB is e.g. glued into the voice coil of the loudspeaker. Different types of loudspeakers can be easily adapted by adjusting the loop gain of the MFB controller. The Motion Feed Back is allowing a frequency independent constant Sound Pressure Level (SPL) – starting far below the initial resonance frequency of the dynamic loudspeaker.

This allows the designer of an active loudspeaker box to become completely independent from the Thiele/Small constraints wrt. the volume of the enclosure.

The AC-PAR75 allows building small loudspeaker boxes with an extreme deep ranging frequency response. 16 Hz are easily achievable, but one has to keep in mind, that, according to physics, the membrane amplitude is quadratic invers to the frequency for a given sound pressure level. To go from a corner frequency of 32 Hz down to 16 Hz needs therefore 4 times the membrane amplitude to generate the same SPL.

For high SPL at very low frequencies, it is therefore recommended to operate several AC-PAR75 with connected loudspeakers in parallel.

Because of the MFB loop, the non-linearity of the connected driver is practically eliminated. THD values below -60 dB (0.1%) are achievable and thermal compression is completely absent.

---

<sup>1)</sup> Implemented with module version 6 and higher

75 W High-End Current Drive Audio Amplifier with MFB\* Control Loop

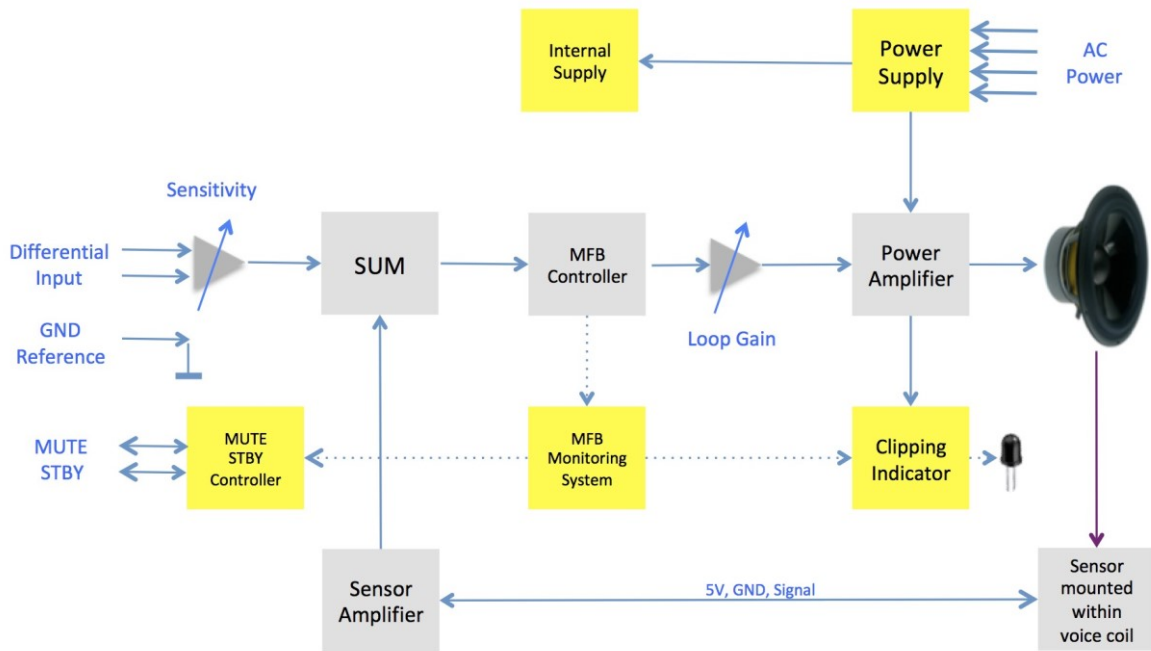

Figure 2: Functional Block Diagram

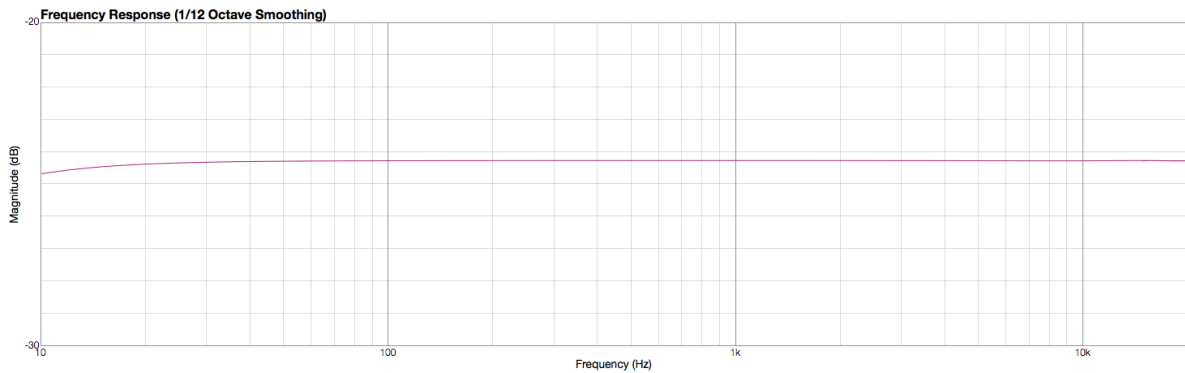

Figure 3: Frequency response in the audio band 1 dB/Division

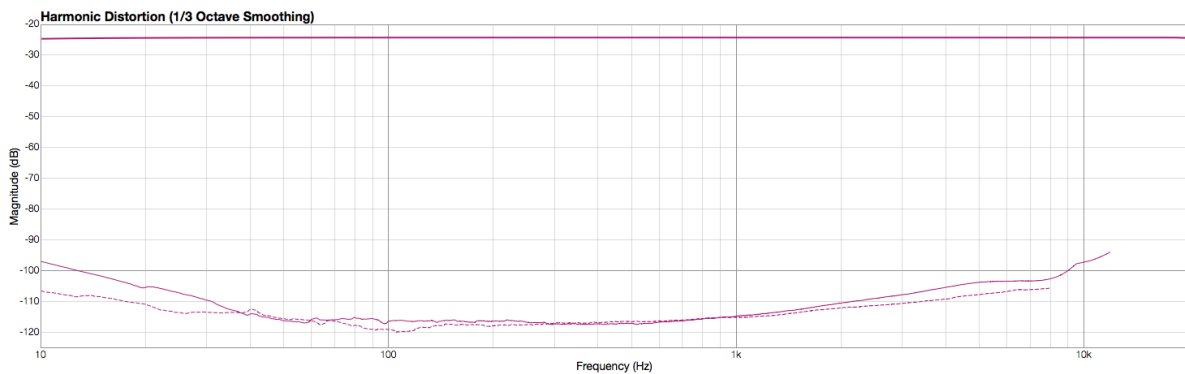

Figure 4: Harmonic Distortions k2 (solid) und k3 (dashed) 10 dB/Div

## 75 W High-End Current Drive Audio Amplifier with MFB\* Control Loop

### Absolute Maximum Ratings ( $T_{amb} = 25^{\circ}\text{C}$ ; unless otherwise specified)

Symbol	Parameter	Min. Value	Max. Value	Unit
$V_S$	AC Supply Voltage (two symmetrical transformer windings)		2 x 31	Vrms
$V_1$	$V_{standby}$ vs. GND	-0.3	+16	V
$V_2$	$V_{MUTE}$ vs. GND	-0.3	+16	V
$I_0$	Peak Output Current		10	A
$T_{op}$	Operating Ambient Temperature Range	0	+70	$^{\circ}\text{C}$
$T_{stg}, T_j$	Storage and Junction Temperature	-10	+125	$^{\circ}\text{C}$

Stresses beyond those listed under "Absolute Maximum Ratings" may cause permanent damage to the module.

### Electrical Characteristic ( $R_L = 8\Omega$ ; $T_{amb} = 25^{\circ}\text{C}$ ; $f = 1\text{kHz}$ ; $V_S = 30\text{VAC}$ ; unless otherwise specified)

Symbol	Parameter and Condition	Min	Typ	Max	Unit
$V_S$	AC Supply Voltage Range Two identical transformer windings, or mid tapped secondary winding	21 for 4 Ohm Load		29 for 8 Ohm Load	Vrms
$I_q$	AC Quiescent Current (during MUTE) AC Quiescent Current (during STBY)		60 20	80 35	mA
$P_o$	RMS Continuous Output Power $d = 1\%$ , $R_L = 4\ \Omega$ Mechanical interface at $25^{\circ}\text{C}$	75	80	100	W
THD	Total harmonic distortion $P_O = 5\ \text{W}$ , $f = 1\ \text{kHz}$ , $8\ \Omega$ resistive Load		0.002		%
<b>Audio Input</b>					
$R_{id}$	Differential Input Resistance		25k		$\Omega$
$R_{i0}$	Input Resistance to GND	10k		20k	$\Omega$
$V_{CM}$	Input Common Mode Range		$\pm 5$		V
$V_{IS}$	Input Sensitivity (for full output power) Adjustable via 10 turn potentiometer	200 mV		2 V	V
<b>Standby &amp; MUTE Function</b>					
$V_{on}$	Standby/MUTE ON Threshold			1.2	V
$V_{off}$	Standby/MUTE OFF Threshold	3.0			V
$ATT_{st-by}$	Standby Attenuation	70	90		dB
$ATT_{Mute}$	MUTE Attenuation	60	80		dB
$I_{IN}$	Input Current $V_{IN} = 0\text{V}$	-0,4			mA
$I_{sink}$	Input Pull Down Capability for Synchronization			20	mA
<b>External Clip and Status Indicator</b>					
$I_{LED1}$	LED operating current		14		mA
<b>Over Temperature Detection and Turn ON/OFF</b>					
$T_{OFF}$	Switch OFF temperature	70	75	80	$^{\circ}\text{C}$
$T_{ONHY}$	Switch ON Hysteresis		4		K

---

### 75 W High-End Current Drive Audio Amplifier with MFB\* Control Loop

---

#### Description and Application Information

The Power Amplifier is supplied with two equal AC voltages. Two separate windings of the AC transformer are recommended, but also a middle tapped secondary winding can be used.

2 x 21 VAC with a 4 Ohms voice coil, or 2 x 29 VAC with an 8 Ohms voice coil impedance allow typically 80 W continuous output power.

In order to minimize the heat dissipation of the PA it is recommended to choose the AC supply voltage wrt. the load impedance. Appropriate cooling of the PA is required. The thermal resistance junction to case is typically 1 K/W, maximal 1.5 K/W.

The audio input signal is feed to a differential amplifier with high common mode signal rejection in order to avoid ground loops. A connection between the driving amplifier GND and the PA GND is therefore necessary in order to establish a common GND reference.

The PA is DC coupled; however, an offset control loop is constantly active with a very long integration time constant (seconds) to ensure that the current through the voice coil is zero on long term average.

#### **Novelty / Advantage:**

Additional to the electronically generated high output impedance (current drive), an integrated MFB control loop ensures a flat SPL frequency response starting from frequencies far below the original resonance frequency of the loudspeaker.

Any non-linearity of the connected dynamic loudspeaker is reduced to a very low value. THD below -60 dB (0,1%) are achievable. This reduces not only the harmonic distortions of a loudspeaker to an insignificant level, but also the generated non-harmonic intermodulation frequency content, that is much more disturbing wrt. a good listening experience.

A small and low mass sensor PCB is mounted (e.g. glued) into the voice coil of the speaker.

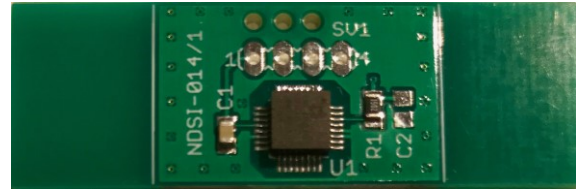

**Figure 5: MFB-Sensor PCB**



**Figure 6: MFB-Sensor PCB glued into the voice coil of a loudspeaker.**

The sensor PCB can fit 16 mm to 50 mm voice coil diameters (if required one can cut from both edges towards the white lines). The chip needs to sit towards the inside of the voice coil (connections on the outside). Customer tailored sensor PCBs are available.

A sequencer for the STBY and the MUTE function is on board and can be synchronized externally, or between several AC-PAR75.

An electronic protection for the speaker and the power amplifier is implemented. In case of an extreme overdrive, or the speaker is moved while the MFB control loop is active, the system is muted.

#### **Customer Adjustments:**

1. Potentiometer for the sensitivity of the amplifier input (SPL-level adjustment)
2. Gain of the MFB control loop. That allows adapting the AC-PAR75 to different speakers.

75 W High-End Current Drive Audio Amplifier with MFB\* Control Loop

**Mechanical Layout (PCB)**

The complete circuit is realized on a four-layer PCB with the dimensions of 65mm x 92mm. The PCB provides two mounting holes with diameter of 3.3mm. The power amplifier IC4 must be thermal connected to a cooling device but mounted electrical isolated. Mounting equipment for Package Multiwatt15V should be used.

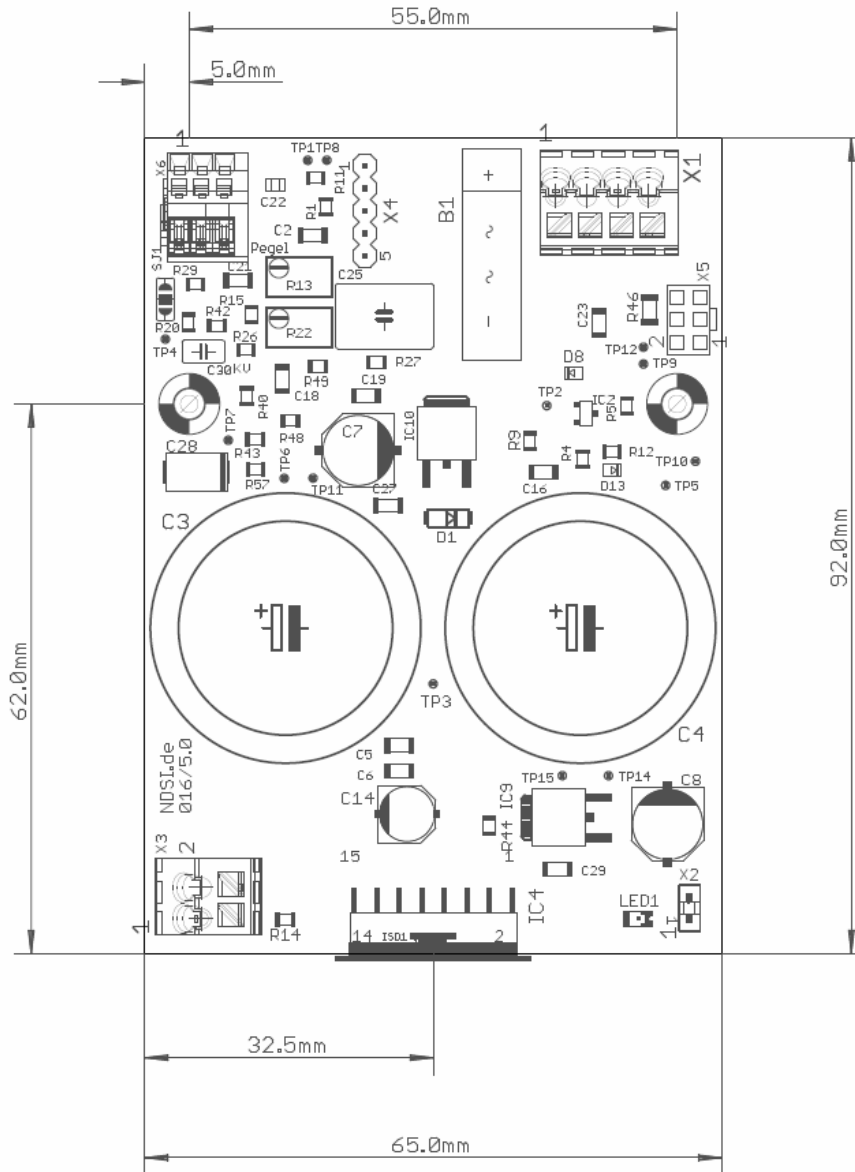

Figure 7: Top view of the PCB with dimensions (V5.0)

75 W High-End Current Drive Audio Amplifier with MFB\* Control Loop

The module will be delivered mounted on a mounting flange shown in Figure 8. The height of the module is typically 63mm including the mounting flange.

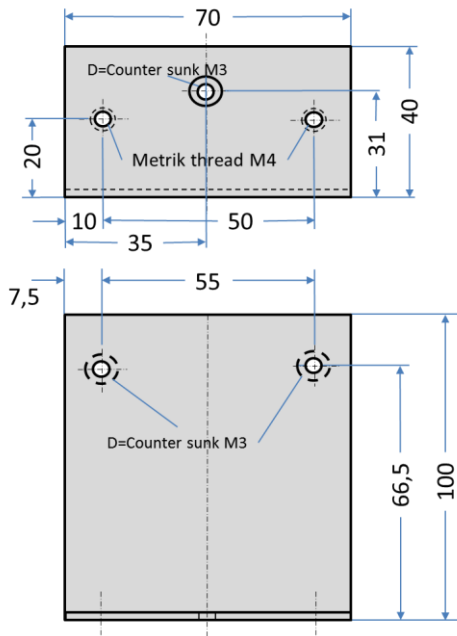

Figure 8: Mounting Flange (Ver. 1)

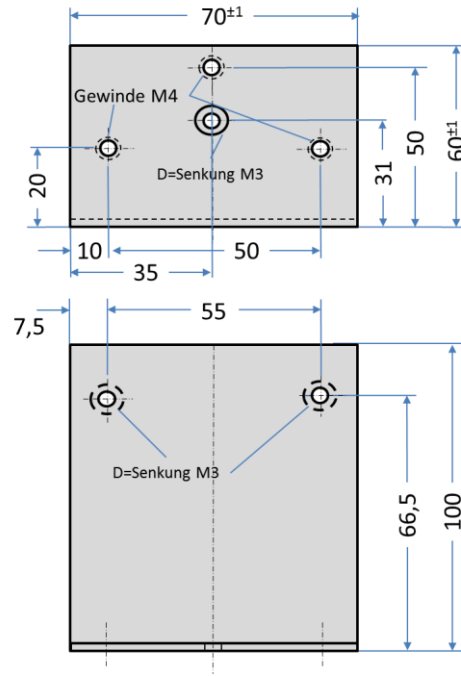

Figure 9: Mounting Flange (Ver. 2)

Old: The mounting flange provides on the small side (upper picture) two metrical threads M4.

Both sides have flat surfaces; there are no protruding elements.

Currently manufactured modules are equipped with an improved mounting flange.

This flange provides an enlarged small side (60mm instead 40mm) and one additional metrical thread M4 for optimized mounting and heat transfer.

Mechanical Characteristic (AC-PAR75 PCB including mounting flange)

Symbol	Parameter	Min	Typ	Max	Unit	
X	Module Dimension X		70		mm	
Y	Module Dimension Y		100		mm	
H	Module Height H	C3/C4 as 4.7mF	59	60	61	mm
		C3/C4 as 10mF	60	63	65	
W	Module Weight (TBC)	C3/C4 as 4.7mF		200	225	g
		C3/C4 as 10mF		246	270	
T	Mounting Flange Material Thickness		4		mm	
M	Flange Material	AlMgSi0,5/EN AW-6060				

The mounting flange is electrically isolated from the amplifier.



75 W High-End Current Drive Audio Amplifier with MFB\* Control Loop

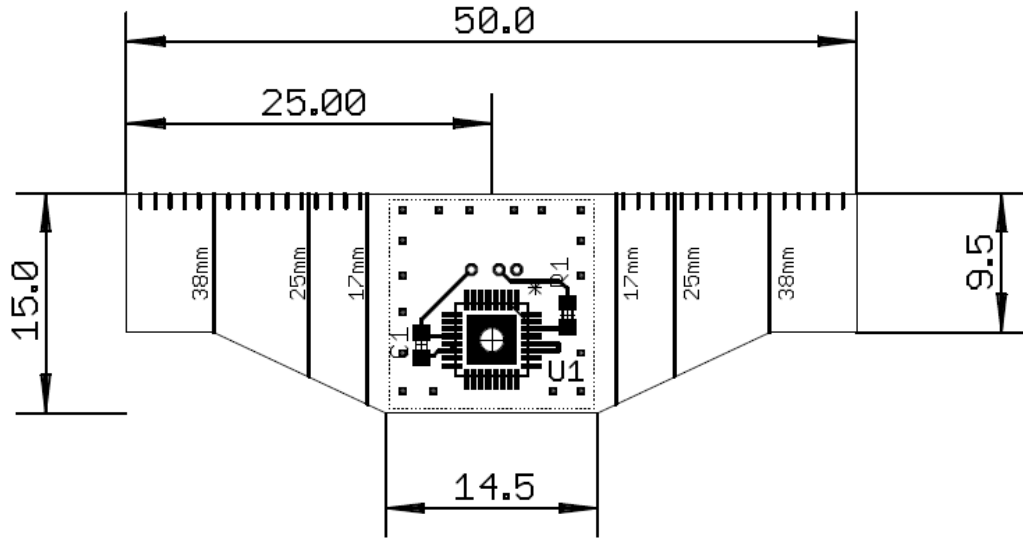

Figure 10: Example of an MFB-Sensor PCB

**Mechanical Characteristic** (16mm – 50mm sensor PCB)

Symbol	Parameter	Min	Typ	Max	Unit
X	Module Dimension X	16	-	50	mm
Y	Module Dimension Y		15		mm
H	Module Height H		3.6		mm
W	Module Weight (TBC)	X = 50mm	2.9		g
		X = 16mm	1.9		

Given module weight without wire set

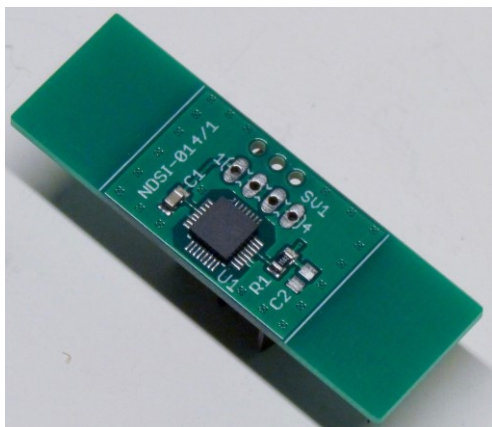

Figure 11: MFB-Sensor PCB with 50mm X-dimension

Can be cut from both sides towards the white lines

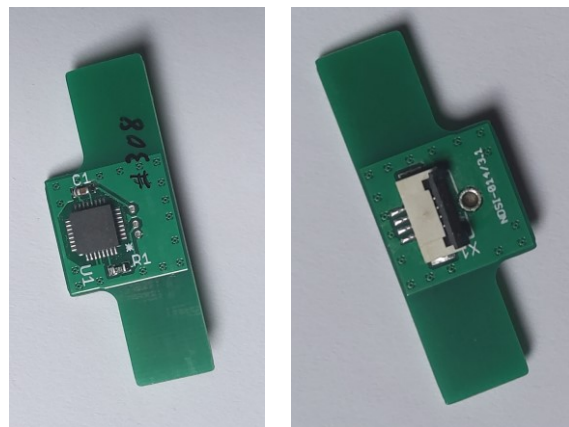

Figure 12: MFB-Sensor PCB with flex-connector on the rear side

---

## 75 W High-End Current Drive Audio Amplifier with MFB\* Control Loop

---

The sensor PCB is deliverable in various dimensions down to a length of 16mm (X-dimension).

*Note: Pin number 1 of the acceleration sensor must be mounted into the driver pointing away from pole piece.*

### WARNINGS

- Any external power supply used with this module shall comply with relevant regulations and standards applicable in the country of intended use.
- This product should be operated in a well-ventilated environment, and if used inside a case, the case should not be covered or should provide enough room for proper ventilation/cooling. Alternative the module could be mounted on a stable, flat, conductive surface for additional cooling purpose.
- The connection of incompatible devices to the module may affect compliance, result in damage to the unit, and invalidate the warranty.
- All peripherals used with this product should comply with relevant standards for the country of use and be marked accordingly to ensure that safety and performance requirements are met. These articles include but are not limited to power supply, amplifiers, programming adapters and other external elements.
- The cables and connectors of all peripherals used with this product must have adequate insulation so that relevant safety requirements are met.

### SAFETY INSTRUCTIONS

To avoid malfunction or damage to this product, please observe the following:

- Handle only in an environment which is protected against Electro Static Discharge (ESD) to avoid possible damage of the sensitive parts.
- Do not expose to water or moisture, or place on a conductive surface whilst in operation.
- Do not expose to heat from any source; this module is designed for reliable operation at normal ambient temperatures.
- Take care whilst handling to avoid mechanical or electrical damage to the printed circuit board and connectors.
- Whilst it is powered, avoid handling the printed circuit board, or only handle it by the mounting flange to minimize the risk of electrostatic discharge damage.





### 75 W High-End Current Drive Audio Amplifier with MFB\* Control Loop

#### Electrical Interfaces

##### Connector Types and Interface Description (PCB Version 6 and before)

Connector	Parameter/Signal	Typ	Wire Size
<a href="#">X1</a>	AC Power Supply	WAGO 250-204	1,0 – 1,5mm <sup>2</sup> AWG 17-15
<a href="#">X2</a>	Connector for external clipping LED indicator (option)	Pin Header 2 RM 2,54mm	(Jumper)
<a href="#">X3</a>	Speaker Output	WAGO-250-202	1,0 – 1,5mm <sup>2</sup> AWG 17-15
<a href="#">X4</a>	Audio In, MUTE and Standby	Pin Header 1x5 RM 2,54mm <sup>2)</sup>	-
<a href="#">X5</a>	SPI/UPDI- and I <sup>2</sup> C-Interface (reserved)	Pin Header 2x3 RM 2,54mm	-
<a href="#">X6</a>	Interface to MFB sensor	WAGO 233-503	0,08 – 0,5mm <sup>2</sup> AWG 28-20

##### Connector Types and Interface Description (PCB Version 7 and later)

Connector	Parameter/Signal	Typ	Wire Size
<a href="#">X1</a>	AC Power Supply	WURTH ELEKTRONIK 691321300004 4-Pol; RM 3.81	1,0 – 1,5mm <sup>2</sup> AWG 17-15
<a href="#">X2</a>	Connector for external clipping LED indicator (option)	Pin Header 2 RM 2,54mm	(Jumper)
<a href="#">X3</a>	Speaker Output	WURTH ELEKTRONIK 691321300004 2-Pol; RM 3.81	1,0 – 1,5mm <sup>2</sup> AWG 17-15
<a href="#">X4</a>	Audio In, MUTE and Standby	Pin Header 1x5 RM 2,54mm <sup>3)</sup>	-
<a href="#">X5</a>	SPI/UPDI- and I <sup>2</sup> C-Interface (reserved)	Pin Header 2x3 RM 2,54mm	-
<a href="#">X6</a>	Interface to MFB sensor	WAGO 233-503	0,08 – 0,5mm <sup>2</sup> AWG 28-20

##### Interface: AC Power Supply and Connector Pinout (X1)

X1 Pin	Parameter/Signal	Remark
L1	AC Input A (or negative DC supply)	Connect external transformer as shown in Figure 17. For proper power drop detection take care of polarity in case of DC supply.
L2	Return A, internally connected to L3	
L3	Return B, internally connected to L2	
L4	AC Input B (or positive DC supply)	

<sup>2)</sup> Recommended connector type: Molex 22-01-2057, crimp terminals 2759 or 4809

<sup>3)</sup> Recommended connector type: Molex 22-01-2057, crimp terminals 2759 or 4809

75 W High-End Current Drive Audio Amplifier with MFB\* Control Loop

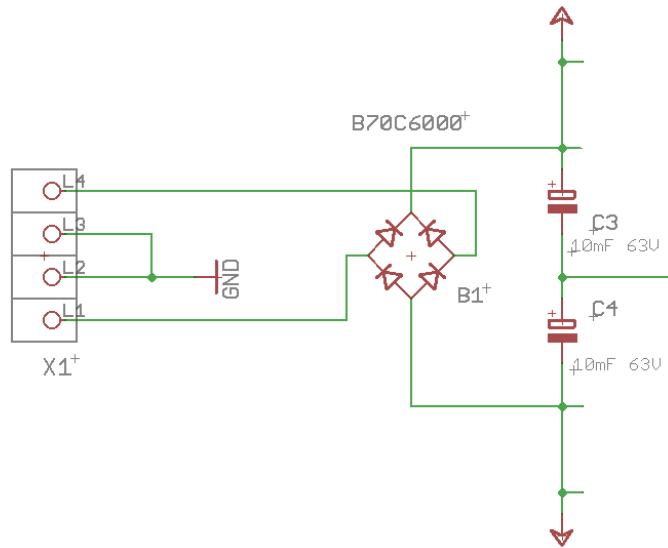

Figure 13: AC Input Circuit Diagram (PAZ75)

Interface: Optional Clipping and Status Indicator LED Connector Pinout (X2)

The PA offers a clipping and status indication output for a LED. If not used, short the connectors in order to activate the on-board indicator LED (LED1, red), or let the connector open if no indication is required.

X2 Pin	Parameter/Signal	Remark
X2-1	Positive indicator LED output	Connector Open: On-board indicator disabled Connector Closed: On-board indicator active LED: Connect to additional LED for external indication
X2-2	Return of the indicator LED	

The AC-PAR75 (V3) provides a status indication by the internal or optional external LED. This will be used for signaling of different states of the amplifier. In nominal operation the LED is off but it will flash for signaling of certain operating states:

Flashing	Status	Remark
1	AC-PAR75 in MUTE	Module in nominal operation (no failure condition) but output disabled
2	AC-PAR75 in Standby	
3	Sensor Error	Sensor error detected - module switched to STBY
4	Over Temperature	Over temperature detected - module switch to STBY for its own protection

Right after switch on the LED is turned on permanently until the bias condition of the system including the sensor bias is within the pre-defined limits.

### 75 W High-End Current Drive Audio Amplifier with MFB\* Control Loop

With version 6 of the amplifier an auto-adjust for the sensor bias is implemented. The ongoing adjust process is indicated with continuous flashing of the LED with 5 Hz. For more details see section for **Adjustment** .

Remark: After approximately 8 Minutes in MUTE the PA will switch to Standby automatically. The PA status will change autonomously from STBY to MUTE and changes to active as soon as the external MUTE signal goes high again.

A clipping of the output of the amplifier as a result of an excessive output signal will be detected by the processor, which in turn switches the system into MUTE for one second.

In case the excessive output signal persists after returning to the active mode, the MUTE process will be activated again. The MUTE time will be extended for each cycle up to maximum 10 seconds, when the clipping takes place several times within a short time period.

Such a clipping initiated MUTE will be indicated by the LED, which is permanently on during the MUTE time.

In case of a continuous flashing of the LED with 1.5 Hz right after power-on, please check the DC-Polarity as given for [X1](#).

#### Interface: Speaker Output Connector Pinout (X3)

X3 Pin	Parameter/Signal	Remark
L1	Speaker Positive Output	<b>L2 must not be connected to Ground</b>
L2	Speaker Return	

*Note: May be inverted for some older versions of the amplifier and is dependent of the MFB-Sensor orientation.*

#### Interface: Audio In and Control Connector Pinout (X4)

X4 Pin	Parameter/Signal	Remark
1	MUTE	Connect to external STBY and/or MUTE driver if required (see chapter below for more details)
2	Standby (STBY)	
3	GND	Provides the ground reference (SP)
4	NF (Audio) Input negative	Differential audio input
5	NF (Audio) Input positive	

*Note: In some constellations it is recommended to keep Pin 3 unconnected (see grounding application note AC-AN-001)*

---

### 75 W High-End Current Drive Audio Amplifier with MFB\* Control Loop

---

Interface: SPI/UPDI and I<sup>2</sup>C (X5)

X5 Pin	Parameter/Signal		Remark
	Up to Version V5	Version V6 and later	
1	SPI MISO	UPDI	Unified Program and Debug Interface
2	VCC	VCC	To be used as reference and for external LCD monitor without background illumination (minor load)
3	I <sup>2</sup> C SCL	Spare	Spare; connected to PC5 of the on-board controller
4	SPI MOSI & I <sup>2</sup> C SDA	I <sup>2</sup> C SDA	I <sup>2</sup> C Master Serial Data
5	(SPI) RESETn	I <sup>2</sup> C SCL	I <sup>2</sup> C Master Serial Clock
6	GND	GND	System Ground

#### **Standby (STBY) and Muting (MUTE)**

The PA offers two independent in/outputs for Standby and Muting. Both functions are active low when used as inputs. They can serve as outputs in order to synchronize other AC-PAR75.

Interface: MFB Sensor (X6)

X6 Pin	Parameter/Signal	Remark
1	Sensor Supply (5V)	MFB-Sensor Interface
2	GND/Return	
3	Sensor Signal	

#### **Standby (STBY) and Muting (MUTE)**

The PA offers two independent in/outputs for Standby and Muting. Both functions are active low when used as inputs. They can serve as outputs in order to synchronize other AC-PAR75.

An external driver for STBY and MUTE must be open Collector or open Drain for proper function.

The circuit dedicated to the switching on and off of the amplifier has been carefully optimized to avoid any kind of uncontrolled audible transient at the output during settling of the internal control loops.

If not used, both control inputs may be left open. In that case the PA will be active about 5 (TBC) seconds after power on. It will use an internally controlled power down sequence as soon as external power is switched off.

If connected in parallel with further PAs, a time wise synchronized activation / deactivation of all PAs is ensured.

In case of an external control of STBY and/or MUTE the following steps during the ON/OFF sequence are recommended:

Power ON-Sequence:

1. Supply AC power to the PA – settling of internal control loops
2. Deactivation of STBY → Quiescent current stabilizes to its nominal value

75 W High-End Current Drive Audio Amplifier with MFB\* Control Loop

- Deactivation of MUTE → Signal is present at the output

Power OFF-Sequence:

- Activation of MUTE
- Activation of STBY
- Switch off of the AC power supply

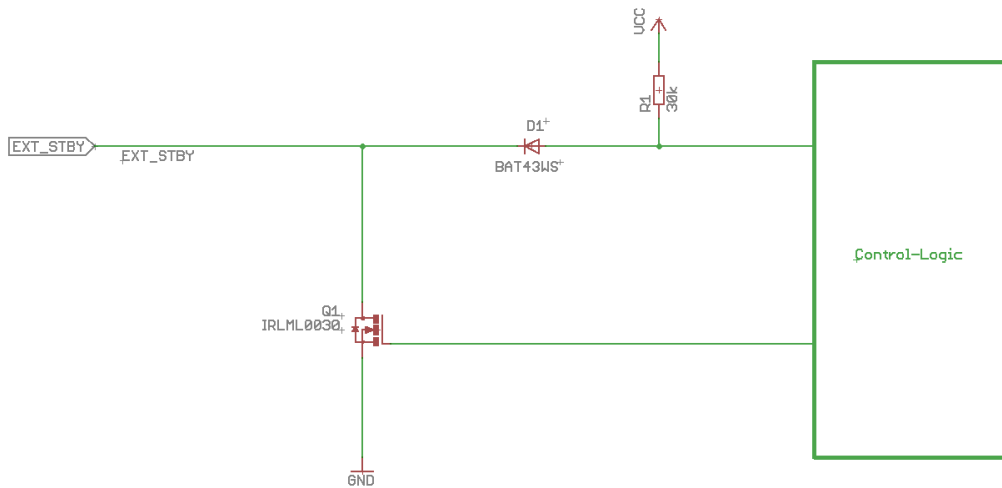

Figure 14: Input/Output Interface for Standby (STBY) or Mute (MUTE)

**Audio IN**

The drive module offers a differential Input circuit with high common mode suppression.

The driving impedance of the AC-PAR75 should be close to zero for both inputs in order to achieve the maximum common mode suppression.

Recommendation: Connect X4-4 to the Ground (GND) of the driving side of a single ended driver stage and drive X4-5 by the output of the driving operational amplifier.

Ensure a common GND reference of the driving amplifier and the PA by an appropriate connection between these two Grounds. X4-3 is connected to the PA GND and must be used for this purpose (see also Figure 17). See application note AC-AN-001 for more details to proper grounding implementation in various systems.

## 75 W High-End Current Drive Audio Amplifier with MFB\* Control Loop

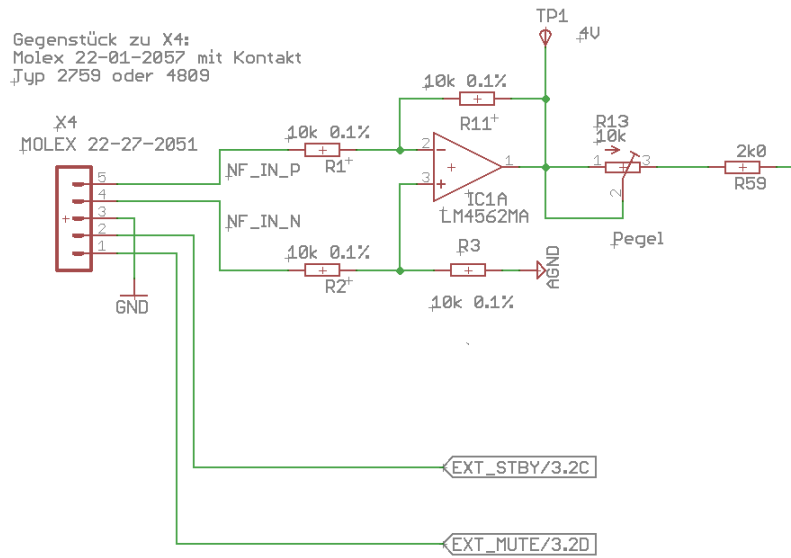

**Figure 15: Audio Input Interface (V5)**

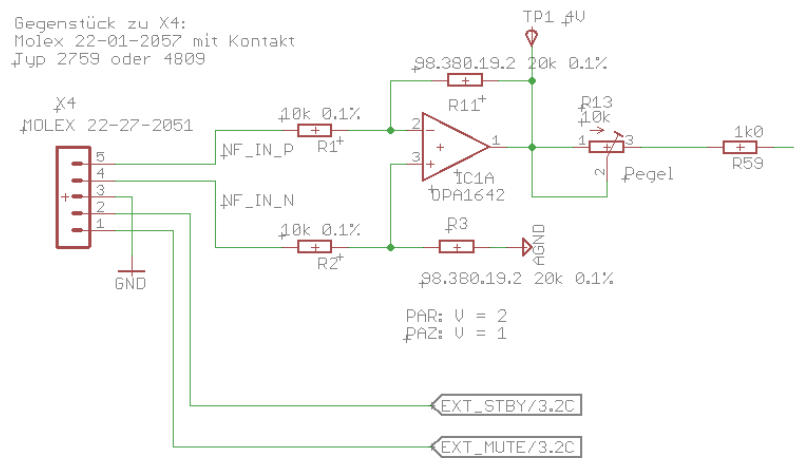

**Figure 16: Audio Input Interface (V6 and later)**

75 W High-End Current Drive Audio Amplifier with MFB\* Control Loop

Typical Operation of the Drive Module

Figure 17 shows the typical implementation of the AC-PAR75

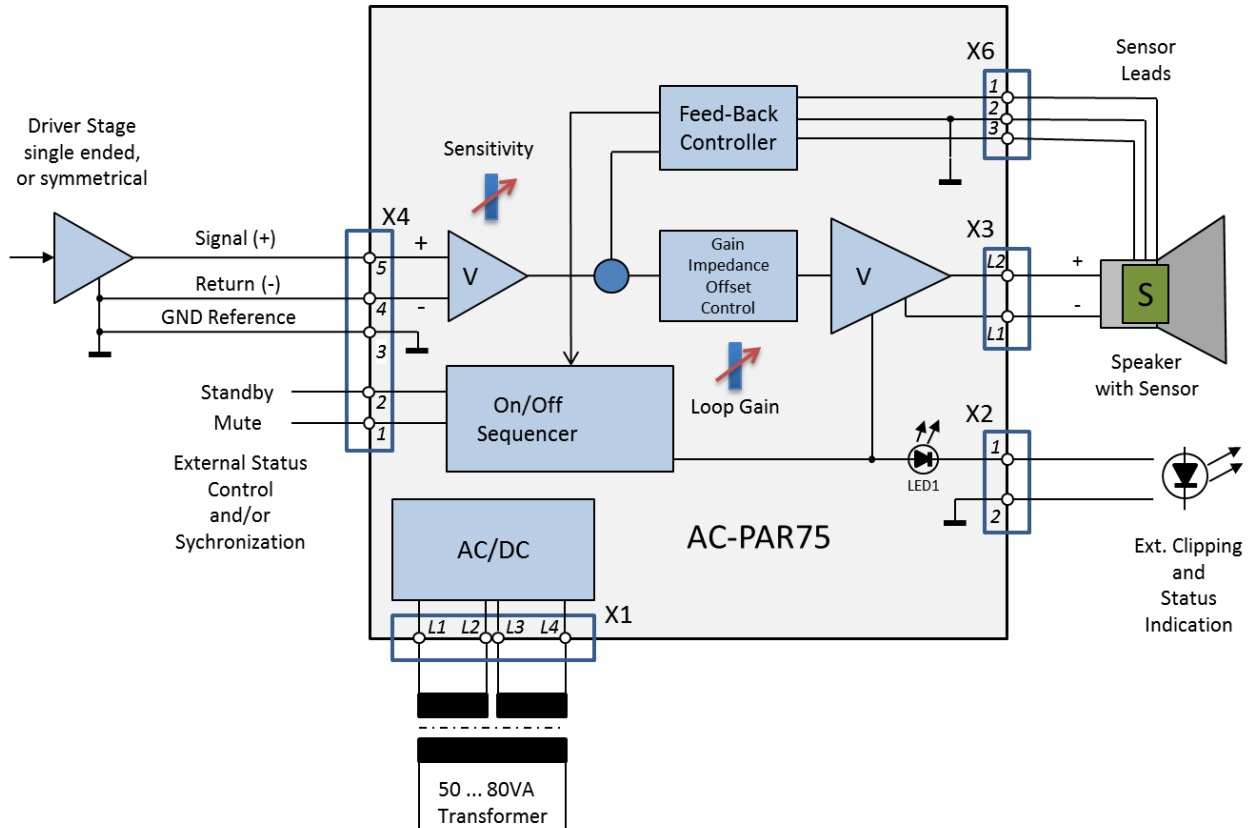

Figure 17: Typical Implementation of the Module AC-PAR75



---

 75 W High-End Current Drive Audio Amplifier with MFB\* Control Loop
 

---

**Proposed Adjustment Procedure**

1. Set the sensitivity adjustment potentiometer (R13) to minimum (counter CW)
2. Optionally bridge X2 pin 1 and 2 in order to enable the on-board clipping indicator LED (default configuration)
3. Connect the secondary windings of the transformer (Figure 17)  
L2 and L3 are internally connected, L1 and L4 need to be 180 degrees out of phase wrt. L2 and L3.
4. Connect the dynamic loudspeaker to the AC-PAR75 X3
5. Connect the MFB feedback leads to connector X6 of the AC-PAR75
6. Power the circuit and disable MUTE and STBY. If MUTE and STBY are not externally controlled, the AC-PAR75 switches automatically into the active mode after few seconds.
7. Without input signal increase the MFB feedback loop gain (R45 respectively R22) to a level, where the speaker tends to show self-oscillation – decrease the MFB loop gain to a stable value.

AudioChiemgau recommends using the SPL noise spectrum as indicator for the MFB loop gain. By watching the SPL noise spectrum while increasing the MFB gain one can recognize a noise peak at e.g. 8 kHz. Adjust this noise peak about 3 dB above the noise floor.

8. Apply the input signal and increase the sensitivity (turn R13 clock wise) to the desired level  
*Recommendation for system with AC-DAP01: Apply input signal with 50 Hz and 200mVp; then adjust R13 to 400mVp on TP4.*

**For AC PAR75 Version 5 and earlier: Please check in combination with the assigned MFB-Sensor or in case the amplifier keeps in Bias-Search-Mode (LED remains on after power on) the voltage at TP8 (against module ground on TP3 or X4/3):**

**Voltage at TP8 <-4V → Close Jumper SJ1 1-2**

**Voltage at TP8 >+4V → Close Jumper SJ1 2-3**

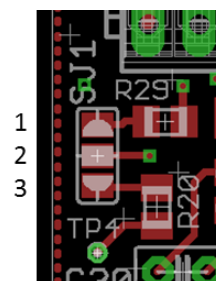
**For AC-PAR75 Version 6 and later:**

Version 6 provides an auto-adjust process to compensate a wide range of sensor offset voltages. If necessary, an adjust process will be initiated by the processor after power-up of the module. During this phase no input signal should be applied. In case the adjust procedure is in progress the on-board LED flashes fast with approximately 5 Hz. The adjust procedure takes about 40 seconds and the determined value will be stored in the on-board EEPROM. After restart of the module the stored value will be used to offer a quick readiness. This process will be activated only for a new combination of sensor and amplifier module or after a reorientation of the sensor module itself (e.g., from vertical to horizontal orientation or vice versa).

The duration of the adjustment process depends on the preset of the MFB loop gain.

With F/W 4D02 and later: In case the system is in mute condition the on-board controller tries to optimize the MFB-Sensor bias point. Therefore every 15 seconds the settled adjustment value will be

---

## 75 W High-End Current Drive Audio Amplifier with MFB\* Control Loop

---

increased or decreased in minor steps to approximate the best value. This may compensate any possible temperature drift and aging processes. The optimized value will be stored internally as well.

### Caution:

1. The AC-PAR75 is a DC coupled power amplifier. Any DC-Voltage at the input will therefore appear amplified at the output. The offset control loop will eliminate small DC voltages present at the input with a long time constant (seconds). Larger DC voltages at the input, however, would saturate the offset control loop.
2. Do not leave the MFB loop in a self-oscillation mode. This may harm the connected loudspeaker. Clipping and over-temperature are monitored and would shut down the amplifier to protect the electronics module and the loudspeaker chassis.
3. Do not break/open the MFB loop during operation. This would result in excessive membrane excursions, as the loop gain is very high. Clipping is monitored and would shut down the amplifier to protect the electronics module and the loudspeaker chassis.
4. Do not move / displace the speaker when the MFB control loop is active. This would lead to excessive membrane excursions.  
A protection circuit would switch the PA to MUTE in that case after a short time interval.

---

 75 W High-End Current Drive Audio Amplifier with MFB\* Control Loop
 

---

**Actions of AC-PAR75 Monitoring and Control Processor**

Applicable for PCB version 3 and later.

**Power-On Sequence:**

After supplying power to the AC-PAR75 the on-board microprocessor with its firmware starts the power-on sequence.

This includes mainly the asymptotic approach of the bias point for the MFB control loop. The bias point will be expected by the controller in a firmware defined window. After this and an additional short delay STBY and then MUTE is disabled. During this bias point verification, the on-board LED is constantly on. The AC-PAR75 is now active and further connected AC-PAR75 or AC-PAZ75 will be synchronized.

In case the bias point of the MFB control loop is not in the expected window, the on-board processor initiates an auto-adjustment as described before. During this activity the LED flickers with approximately 5 Hz as long as the adjustment takes place (round about 40 seconds depending on the MFB loop gain).

The determined value is stored within the on-board EEPROM for the next start of the module. This implementation allows the amplifier to turn silently on within a very short time.

**Active Mode:**

While in the active mode, the MFB control loop is constantly monitored as well as the board temperature. In case one of these values leaves a firmware defined window, the amplifier switches into MUTE and then STBY. Connected amplifiers are synchronized. Flashing of the LED signals different operating modes.

Flashing	Status	Remark
1	AC-PAR75 in MUTE	Module in nominal operation (no failure condition) but output disabled
2	AC-PAR75 in Standby	
3	Sensor Error	Sensor error detected - module switched to MUTE/STBY
4	Over Temperature	Over temperature detected - module switch to MUTE/STBY for its own protection
1,5 Hz	Permanently	Wrong polarity of DC-Supply
5 Hz	For approximately 40 seconds	Auto-Adjustment in progress (V6 and later)
ON	Permanently	Auto-Adjustment failed – system in hold
Dimmed on	Permanently	Fuses not correct (please contact manufacturer)

---

## 75 W High-End Current Drive Audio Amplifier with MFB\* Control Loop

---

**Overdrive Situation (Clipping):**

In case of overdriving the amplifier clipping of the output is detected by the microprocessor. The amplifier is switched into MUTE for one second. If the overdrive persists after re-activation of the amplifier, the process repeats itself; however, the waiting time is incremented until after many cycles 10 seconds waiting time are reached. The waiting time is decreased successively after the fault condition disappears. The LED is constantly on during MUTE.

**AC Power Loss:**

In case of loss of AC or DC power the microprocessor switches the amplifier into MUTE and then into STBY while the DC power from the on-board capacitors is still available.

During this process some parameters are stored in the on-board EEPROM for re-use after power on.

**Auto-Standby Function:**

In case the amplifier is commanded via the MUTE line into MUTE, the microprocessor autonomously activates STBY after 5 Minutes in sync with connected amplifiers. When the external MUTE command disappears the switch-on sequence is initiated in sync with all connected amplifiers.

**Health-Monitoring and Operating Parameters:**

The on-board Control Processor logs in the internal nonvolatile memory section (EEPROM) some operating parameters. This includes the number of switch-on cycles, the number of operating hours, the maximum temperature of the module during operation as well as the number of clipping events.

Additionally, some parameters are also stored within this memory section which will be used during operation. These parameters are defined during initial test but some of them could be adjusted if required.

**Supported Display with Status and Error Information:**

An optional display could be connected to X5 to show any error or status information of the module.

The module uses an I<sup>2</sup>C-Bus on X5.

Please contact AudioChiemgau for further information. The optional display is supported in PCB version 6.1 and F/W 4D00 or higher only.



Figure 18: Default screen for nominal operating of PAR75 (example)

### 75 W High-End Current Drive Audio Amplifier with MFB\* Control Loop

The following parameters are shown on the nominal operating screen:

Display	Value	EEPROM Position	Remark
T	Temperature in °C	-	Current module temperature in °C
TM	Max Temperature in °C	0x06	Max temperature of the module in °C
TP8	Bias Point in DN	0x0A	Operating bias point in 10 Bit digital numbers (DN). This value should be as close as possible to a value of 512 Max Value = 1023
DAC	DAC value	0x1C	10 Bit DAC operating value in DN. This value should be as close as possible to a value of 512 and depends on the sensor offset voltage Max Value = 1023
M	MUTE input	-	Current status of the MUTE input L = MUTE active; H = no MUTE condition
S	STBY Input	-	Current status of the STBY input L = STBY active; H = no STBY condition
C	Counted Clipping	0X08	Accumulated number of registered signal clippings
ON	Counted ON cycles	0x00	Accumulated number of counted power ON cycles Max Value = 65535
OP	Operating time	0x02	Accumulated operating hours in hours and minutes Max Value for hours = 65535

The following information will be shown during auto adjust process:

Display	Value	Remark
TP8	Current Bias Point in DN	Successive approximation value for bias point in 10 Bit digital numbers (DN)
DAC	Current DAC value	Commanded 10 Bit DAC value in DN
Bit-Number	Current in SAR process	Counts down from 9 down to 0
MOD	Type of Module	"PAR" for PAR75
VER	Firmware Version	Currently implemented and running firmware version

In case of a failure mode or an error condition the following messages are possible:

---

 75 W High-End Current Drive Audio Amplifier with MFB\* Control Loop
 

---

Message	Remark
FUSES not OK	Programmed Fuses not in default condition <ul style="list-style-type: none"> <li>Contact manufacturer</li> </ul>
DC polarity wrong	In case the module is supplied with DC, the polarity of the supply is wrong <ul style="list-style-type: none"> <li>Turn positive and negative supply connected on X1</li> </ul>
Auto adjust fail	Auto adjust procedure did not find a solution for proper operating <ul style="list-style-type: none"> <li>Check connected sensor</li> </ul>

**Firmware Update:**

If necessary, the firmware of the on-board controller may be easily updated via the SPI/UPDI interface provided on the connector X5.

Used and implemented type of microcontrollers:

PCB Version	Implemented Microcontroller	Remark
V1	No Controller on-board	No option for programming
V2		
V3	ATtiny84A-20SSU	In-System-Programmable via SPI
V4		
V5		
V6	ATtiny3217-MFR	In-System-Programmable via UDI

---

AudioChiemgau reserves the right to change technical data